



Quantum Digital USB Flash Drive

General Description and Key Features

Quantum Digital's Industrial Grade USB Flash Drive (UFD) is more than just portable storage. Tailored for industrial applications that require high reliability and data throughput, it provides non-volatile, industrial grade solid-state storage in a thumb-drive package. In addition, laser-etched manufacturing information allows for lot traceability and complete info on the Bill of Materials.

The Industrial Grade UFD is available in an ESD rated enclosure (with LED light indicator) for applications that require NEBS Level 3 compliancy. The ESD-rated enclosure has been tested for immunity from ESD for 8KV contact and 15KV air.

Quantum Digital's U2, cutting edge, USB 2.0 flash memory controller is incorporated in the Industrial Grade UFD, providing high data integrity and endurance. The flash management software that is embedded in the controller emulates a hard disk, enabling read/write operations that are identical to a standard, sector-based hard disk. Sophisticated wear leveling algorithms ensures greater flash endurance, while automatic bad block management and a built-in ECC Engine guarantee the highest data reliability. Based on the BCH error correct algorithm, the ECC engine can correct up to 6-bit errors per 512 bytes.

High performance, high reliability and a controlled Bill-Of-Materials make the Industrial Grade UFD the product of choice in industrial applications, such as POS Workstations, Networking Equipment, automotive diagnostics and Industrial PCs.

The UFD is fully customizable to add a company logo, graphic design, or text. In addition, QDT offers value-added services to OEM customers, such as pre-loaded content and controlled Bill of Materials.

Capacity: 1GB - 128GB
USB 2.0 Compliant
LED activity indicator
Customizable for
logo/graphic design

High Reliability:

Guaranteed 2M
Program/Erase Cycles

Advanced Wear-Leveling

BCH ECC Engine corrects up
to 6 bits/512 Bytes errors

Automatic Bad Block
Management
Single Level Cell (SLC)
NAND Flash Memory

10 Year Data Retention

NEBS Level 3 compliant for ESD
8KV Contact, 15KV Air

Lot Traceability

Commercial and Extended
Operating Temperature

RoHS-6 Compliant

Ordering Information: USB Flash Drive

Ordering Information:

Part Number	Capacity
QDUFD-1GU2U(I)	1 Gbytes
QDUFD-2GU2U(I)	2 Gbytes
QDUFD-4GU2U(I)	4 Gbytes
QDUFD-8GU2U(I)	8 Gbytes
QDUFD-16 GU2U(I)	16 Gbytes
QDUFD-32 GU2U(I)	32 Gbytes
QDUFD-64 GU2U(I)	64 Gbytes
QDUFD-128GU2U(I)	128 Gbytes

QDUFD = QDT standard USB Flash Drive part number prefix.

G = proceeding capacity (xxx) is in Gigabytes (G).

U2 = QDT U2 controller.

U = RoHS-6 compliant

Part numbers without (I) = Commercial temperature range (0°C to 70°C).

I = Extended temperature range (-40°C to 85°C).

M= MLC (Multi Layer Chip) Blank= SLC (Single Layer Chip)



This document is for information use only and is subject to change without prior notice. QDT assumes no responsibility for any errors that may appear in this document, nor for incidental or consequential damages resulting from the furnishing, performance or use of this material. No part of this document may be reproduced, transmitted, transcribed, stored in a retrievable manner or translated into any language or computer language, in any form or by any means, electronic, mechanical, magnetic, optical, chemical, manual or otherwise, without the prior written consent of an officer of QDT

All parts of the QDT documentation are protected by copyright law and all rights are reserved.

Product names mentioned herein are for identification purposes only and may be trademarks and/or registered trademarks of their respective companies.

Revision History:

<i>Rev.</i>	<i>Description</i>	<i>Update</i>
<i>01V0</i>	<i>Preliminary version</i>	<i>2009/03/02</i>

CONTENTS

1. INTRODUCTION	3
1.1. SCOPE	4
1.2. SYSTEM FEATURES	4
1.3. TECHNOLOGY INDEPENDENCE - STATIC WEAR LEVELING	4
1.4. ECC TECHNOLOGY	4
1.5. CONFORMAL COATING	5
2. PRODUCT SPECIFICATIONS	6
2.1. SYSTEM ENVIRONMENTAL SPECIFICATIONS	6
2.2. SYSTEM POWER REQUIREMENTS	6
2.3. SYSTEM PERFORMANCE	6
2.4. SYSTEM RELIABILITY	7
2.5. PHYSICAL SPECIFICATIONS	7
2.6. CAPACITY SPECIFICATIONS	8
2.7. CERTIFICATIONS	8
3. INTERFACE DESCRIPTION	9
3.1. PHYSICAL DESCRIPTION	9
3.2. PIN ASSIGNMENTS	9
4. ELECTRICAL CHARACTERISTICS	10
4.1. ABSOLUTE MAXIMUM RATINGS	10
4.2. RECOMMENDED POWER SUPPLY OPERATION CONDITIONS AND TEMPERATURE	10
4.3. RECOMMENDED EXTERNAL CLOCK SOURCE CONDITIONS	10
4.4. POWER SUPPLY DC CHARACTERISTICS (IDLE MODE)	1

APPENDIX B. LIMITED WARRANTY..... 12

1. Introduction

QDT's Industrial Ruggedized Metal QDT-2010 USB Flash Disk features high capacity and high performance USB 2.0 Flash Disk. The QDT-2010 USB Flash disk is designed with enhanced technology USB 2.0 controller which is designed to provide higher bandwidth for flash memory access. The USB controller also provides the embedded hardware error correction code (ECC), Dynamic / static wear-leveling algorithm and bad block management technology in the chip. The Industrial Rugged Metal QDT-2010 USB Flash Disk specified as 2.0 High Speed Device, Mass Storage Class; USB-IF (USB Implementers Forum), WHQL (Window Hardware Quality Labs), and EMI (Electromagnetic Interference). It can control 8 pieces of flash memory chips; therefore, the SLC Flash Disk can support up to 64GB and MLC Flash Disk up to 128GB.

In addition to being as high speed USB Flash Disk, the controller provides embedded processor, internal marked ROM, data SRAM, USB 2.0 device controller and USB 2.0 PHY. Data swap between different interfaces can be done very efficiently by DMA without CPU involvement. Based on that efficient and advanced architecture, the QDT-2010 USB Flash Disk is featured with high performance. The SLC USB Flash disks' sequential read / write performance can reach

30MB/30MB per second; the MLC USB Flash disk is up to 30MB/29MB per second. The Industrial Rugged Metal QDT-2010 USB Flash disks SLC are available in 16GB to 64GB; MLC USB Flash disks from 32GB to 128GB. However, MLC USB Flash Disk supports standard operating temperature 0° C ~ 70° C only and SLC USB Flash disk supports optional standard operating temperature 0° C ~ 70° C and industrial grade operating temperature -40° C ~ 85° C.

The Industrial Rugged Metal QDT-2010 high capacity & high performance USB Flash Disk - also offers unique customization for OEM customers by laser markings.

Figure--1 shows the block diagram of the used advanced technology of USB flash controller.

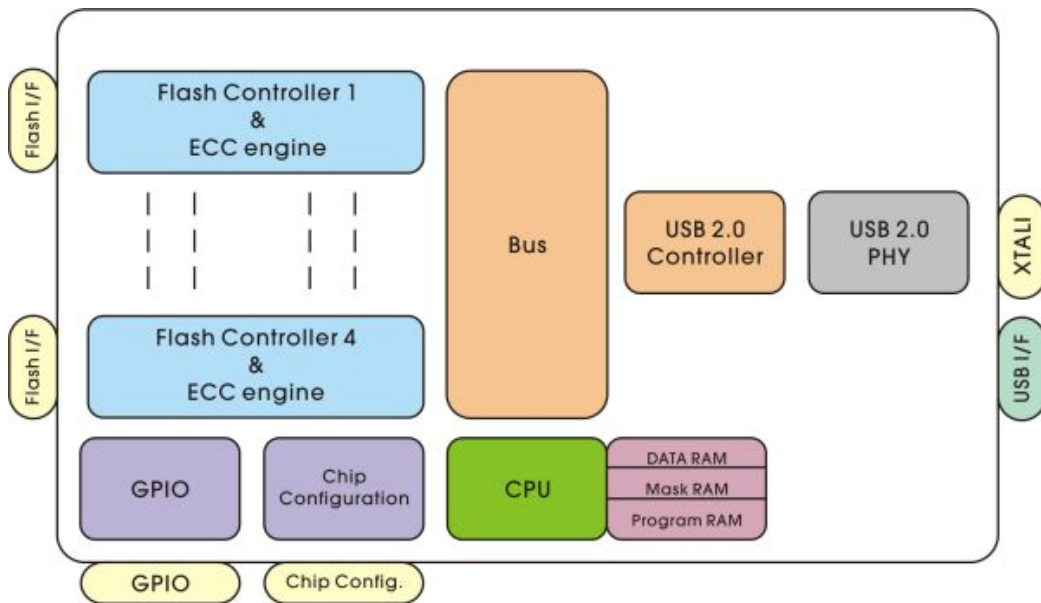

Figure--1: QDT-2010 USB Controller Block Diagram

1.1. Scope

This document describes the features and specifications of Industrial Rugged Metal QDT-2010 high capacity & high performance USB Flash Disk.

1.2. System Features

- Rugged metal USB casing design to endure various rough environments
- Compliant with USB specification 2.0 and downwards compatible to USB 1.0
- SLC supports standard grade operating temperature 0°C to 70°C & industrial grade operating temperature -40° C ~ 85° C
- Complies with Microsoft Vista Ready-Boost® requirement.
- Supports Ready Boost for Microsoft Vista O.S.
- SLC USB Flash Disk capacities from 16GB to 64GB and MLC USB Flash Disk from 32GB to 128GB
- Fixed disk type and optional for removable disk type
- Performance up 30MB/sec

1.3. Technology Independence - Static Wear Leveling

In order to gain the best management for flash memory, Industrial Rugged Metal QDT-2010 high capacity & high performance USB Flash Disk – supports Static Wear Leveling technology to manage the Flash system. The life of flash memory is limited; the management is to increase the life of the flash product.

A static wear-leveling algorithm evenly distributes data over an entire Flash cell array and searches for the least used physical blocks. The identified low cycled sectors are used to write the data to those locations. If blocks are empty, the write occurs normally. If blocks contain static data, it moves that data to a more heavily used location before it moves the newly written data. The static wear leveling maximizes effective endurance Flash array compared to no wear leveling or dynamic wear leveling.

1.4. ECC Technology

Please refer to Figure--2. Figure--2 is a diagram illustrating an allocation method of a spare area in each page of a NAND flash memory, wherein the specific ECC algorithm utilizes a Bose, Chaudhuri and Hocquengham (BCH) ECC algorithm. When a BCH 8 ECC algorithm encodes the data in the NAND flash memory, the parity code generated in the encoding process may occupy 13 bytes of the spare area in each page. When a BCH 15 ECC algorithm encodes the data in the NAND flash memory, the parity code generated in the encoding process may occupy 25 bytes of the spare in each page.

When a BCH 8 algorithm decodes the data in the NAND flash memory, the data can be decoded correctly if the error bit happened in one sector (512 Bytes) is 8. When a BCH 15 algorithm decodes the data in the NAND flash memory, the data can be decoded correctly if the error bit happened in one sector is 15.

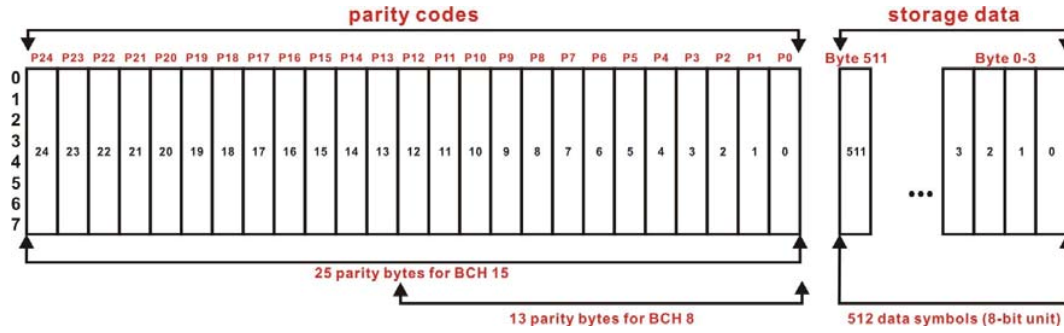

Figure--2: Allocation for ECC Algorithm BCH in NAND Flash

1.5. Conformal Coating

Conformal coating is a protective, dielectric coating designed to conform to the surface of an assembled printed circuit board. Commonly used conformal coatings include silicone, acrylic, urethane and epoxy. QDT applies only silicone on QDT storages products upon requested especially by customers. The type of silicone coating features good thermal shock resistance due to flexibility. It is also easy to apply and repair.

Conformal coating offers protection of circuitry from moisture, fungus, dust and corrosion caused by extreme environments. It also prevents damage from those Flash storages handling during construction, installation and use, and reduces mechanical stress on components and protects from thermal shock. The greatest advantage of conformal coating is to allow greater component density due to increased dielectric strength between conductors.

QDT apply MIL-I-46058C silicon conformal coating.

2. Product Specifications

For all the following specifications, values are defined at ambient temperature and nominal supply voltage unless otherwise stated.

2.1. System Environmental Specifications

Table- 1: Environmental Specification

Temperature	Standard grade operating temp. / non-operating temp.	0°C ~ +70°C / -20°C ~ +80°C
	Industrial grade operating temp. / non-operating temp.	-40°C ~ +85°C / -50°C ~ +95°C
Humidity	Operating & Non-operating:	10% ~ 95% non-condensing
Vibration	Operating & Non-operating:	15G compliance to MIL-STD-810F
Shock	Operating & Non-operating:	1,500 G compliance to MIL-STD-810F

Remark : MLC USB Flash Disk supports standard operating temperature supports 0° C ~ 70° C and non-operating temperature is -20°C ~ +80°C

2.2. System Power Requirements

Table- 2: Power Requirement

DC Input Voltage (VCC) 100mV max. ripple(p-p)		5V±10% via on-board USB port	
NAND flash types		SLC	MLC
+5V Current (Maximum average value)	Idle mode :	90 mA (Max.)	90 mA (Max.)
	Reading mode :	155 mA (Max.)	160 mA (Max.)
	Writing mode :	175 mA (Max.)	180 mA (Max.)

2.3. System Performance

Table- 3: System Performances

Performance (MB/sec)	Sequent Speed (MB/Sec.)			
	Read		Write	
Flash Type	SLC	MLC	SLC	MLC
16GB	29.91	NA	29.00	NA
32GB	29.82	29.15	28.85	28.06
64GB	30.12	29.22	29.24	28.49
128GB	NA	29.70	NA	28.34

Note:

(1). All values quoted are typically at 25°C and nominal supply voltage.

(2). The Max. Performance was tested by SiSoftware Sandra /File Benchmark

2.4. System Reliability

Table- 4: System Reliability

MTBF	>3,000,000 hours
Wear-leveling Algorithms	Static wear-leveling algorithm
ECC Technology	8bit/12bit ECC (8bit/512Bytes and 12bit/512Bytes BCH ECC engines)
Endurance	Greater than 2,000,000 cycles Logically contributed by Wear-leveling and advanced bad sector management
Data Retention	10 years

2.5. Physical Specifications

Refer to Table- 5 and see Figure- 3 for USB Flash Disk physical specifications and dimensions.

Table- 5: Physical Specifications

QDT Industrial USB Flash Disk	
Length:	89.30 mm
Width:	32.00 mm
Thickness:	11.30 mm
Weight:	40 g /1.41 oz

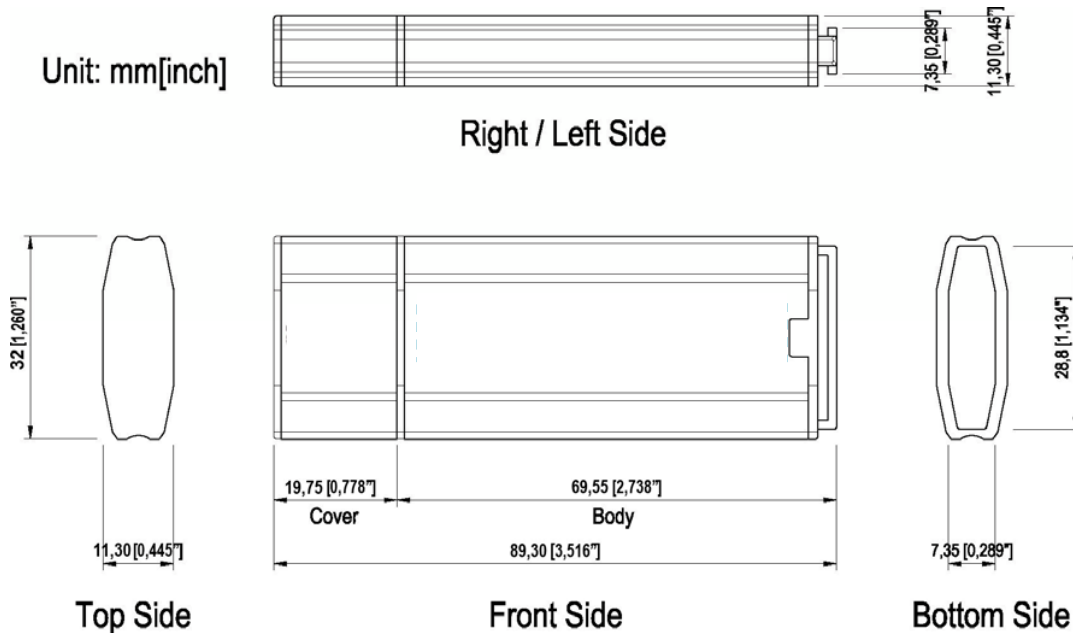

Figure- 3: QDT-2010 USB Flash Disk Dimensions

2.6. Capacity Specifications

INDUSTRIAL RUGGED METAL QDT-2010 high capacity & high performance USB Flash Disk - USB 2.0

Flash Disks built-in mainly Samsung NAND Type SLC Flash memory chips. The Table- 6 shows the equivalent part number of applied Samsung Flash memory chips for each USB Flash Disk.

Table- 6: QDT-2010 USB Flash Disk Configuration vs. Samsung NAND SLC part number

Capacity	Grade	Samsung SLC Flash Memory Part Number * Q'TY	
Flash Type:		SLC flash IC	MLC Flash IC
16GB	Commercial Grade:	K9KAG08UOM-PCB0 *8	NA
	Industrial Grade:	K9KAG08UOM-PIB0 *8	
32GB	Commercial Grade:	K9WBG08U1M-PCB0 *8	K9LBG08U1D-PCB0 *8
	Industrial Grade:	K9WBG08U1M-PIB0 *8	NA
64GB	Commercial Grade:	K9NCG08U5M-PCB0 *8	K9HCG08U5M-PCB0 *8
	Industrial Grade:	K9NCG08U5M-PCB0 *8	NA
128GB	Commercial Grade:	NA	K9HDG08U5M-PCB0 *8
	Industrial Grade:	NA	NA

Note: Above flash part numbers are just for reference only for Samsung equivalent will be used too.

2.7. Certifications

2.7.1 EMC / Verification No.: EM/2007/90094C

QDTINDUSTRIAL RUGGED METAL QDT-2010 high capacity & high performance USB Flash Disk - products meet the requirements of the below standards and hence fulfills the requirements of EMC Directive 2004/108/EC requirements.

Table- 7 – QDTSRUF D Electromagnetic Compatibility

Parameter	Standard
Emission	EN55022 : 1998+A1: 2000+A2:2003 Class B
Immunity	EN55024 : 1998+A1: 2001+A2:2003
	IEC61000-4-2: 1995+A1:1998+A2:2000
	IEC61000-4-3: 2002+A1:2002

2.7.2 FCC / Declaration No.: EM/2007/70044C

In the configuration tested the QDTINDUSTRIAL RUGGED METAL QDT-2010 high capacity & high performance USB Flash Disk - complied with the standards **FCC Part 15: 2006, Subpart B, Class B.**

2.7.3 RoHS

Directive of the European Parliament of the Council on the Restriction of the Use of Certain Hazardous Substances in Electrical and Electronic Equipment, 2002/95/EC (RoHS).

3. Interface Description

3.1. Physical Description

The host is connected to the Industrial Rugged Metal QDT-2010 high capacity & high performance USB Flash Disk - using a Type a male USB type A connector.



Figure- 4: QDT-2010 USB Flash Disk USB Connector Type A

3.2. Pin Assignments

Table- 8 Pin Assignments of USB 2.0

Pin Number	Pin Name	Function
Pin 1	Vcc	Power
Pin 2	USB -	The pairs are used to transmit Address, Data and Command.
Pin 3	USB +	
Pin 4	Vss	Ground

4. Electrical Characteristics

4.1. Absolute Maximum Ratings

Table- 9 Absolute Maximum Ratings

PARAMETER	SYMBOL	CONDITION	MIN	MAX	UNITS
Analog Power Supply	AVDDH		-0.5	6	V
Digital I/O Power Supply	DVDD		-0.5	6	V
Digital I/O Input Voltage	$V_{i(D)}$		-0.4	DVDD 0.4	V
Storage Temperature	$T_{STORAGE}$		-55	140	°C

4.2. Recommended Power Supply Operation Conditions and Temperature

Table- 10 Recommended Power Supply Operation Conditions and Temperature

PARAMETER	SYMBOL	CONDITION	MIN	TYP	MAX	UNITS
Operation Digital Power Supply	PV33		3.0	3.3	3.6	V
	D1V8		1.85	1.9	2.0	V
Operation Analog Power Supply	ASV33		3.0	3.3	3.6	V
	ASV18		1.85	1.9	2.0	V
	AVDDH		3.0	3.3	3.6	V
Ambient Operation Temperature	T_A	For commercial spec.	0		70	°C
Ambient Operation Temperature	T_A	For industrial spec.	-40		85	°C
Junction Temperature	T_J				125	°C
Case Operation Temperature	T_c	For commercial spec. and base on T_A			85	°C
Case Operation Temperature	T_c	For industrial spec. T_A			100	°C
TFBGA 130 Ball 9X9	⊖ JC			7.9		°CW
TFBGA 130 Ball 9X9	⊖ JA			32.7		°CW

4.3. Recommended External Clock Source Conditions

Table- 11 Recommended External Clock Source Conditions

PARAMETER	SYMBOL	CONDITION	MIN	TYP	MAX	UNITS
External reference clock				30		MHz
Clock Duty Cycle			45	30	55	%

4.4 Power Supply DC Characteristics (Idle mode)

Table- 12 Power Supply DC Characteristics (Idle mode)

PARAMETER	SYMBOL	CONDITIONS	MIN	TYP	MAX	UNITS
Digital Power Supply	IPV33	3.3V		6		mA
	IDV18	1.9V		79		mA
USB Analog Power Supply	IAVDDH	3.3V		34		mA
Analog Power Supply	IASV33	3.3V		2		mA
	IASV18	1.9V		120		mA

4.5 I/O DC Characteristics

Table- 13 I/O DC Characteristics

PARAMETER	SYMBOL	CONDITIONS	MIN	TYP	MAX	UNITS
Input low voltage	V _{IL}				0.8	V
Input high voltage	V _{IH}		2.0			V
Output low voltage	V _{OL}		0		0.4	V
Output high voltage	V _{OH}		2.6		3.6	V

4.6 Power Sequence

If external power design is applied, designers should make sure that the 3.3V power rail ramps prior to the 1.8V power rail or at the same time to prevent excessive current leakage. Except for 1.8V power rail, reset signal should be also taken into consideration. Designers should make sure that the 3.3V power rail ramps prior to the reset signal for system normal operating purpose. It is not acceptable if reset signal ramps prior to 3.3V power rail.

If internal power design is applied, 3.3V power rail will ramp prior to or simultaneously with the 1.8V Power rail to prevent excessive current leakage onto the 3.3V power rail.

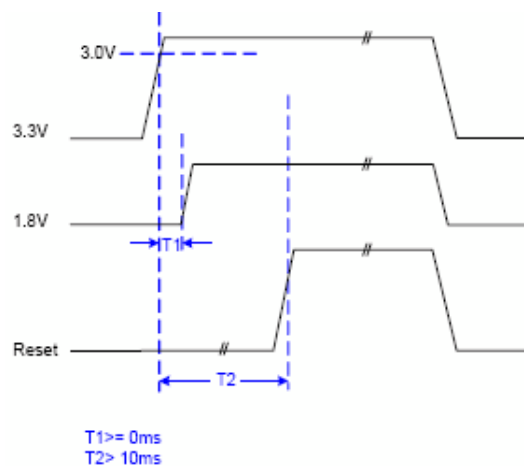

Figure- 5: QDT-2010 USB Flash Disk Power Sequence

Appendix B. Limited Warranty

QDT warrants your Metal USB Flash Disk against defects in material and workmanship for the life of the drive. The warranty is void in the case of misuse, accident, alteration, improper installation, misapplication or the result of unauthorized service or repair. The implied warranties of merchantability and fitness for a particular purpose, and all other warranties, expressed or implied, except as set forth in this warranty, shall not apply to the products delivered. In no event shall QDT be liable for any lost profits, lost savings or other incidental or consequential damages arising out of the use of, or inability to use, this product.

BEFORE RETURNING PRODUCT, A RETURN MATERIAL AUTHORIZATION (RMA) MUST BE OBTAINED FROM QDT.

Product shall be returned to QDT with shipping prepaid. If the product fails to conform based on customers' purchasing orders, QDT will reimburse customers for the transportation charges incurred.

Appendix A. Ordering Information

1. Part Number

Capacity	0° C~ 70° C	-40° C~ +85° C	MLC Flash
16GB			
32GB			
64GB			
128GB			

